

Vertical Movement System
VMSTM

V4MF5
Combo
Floor Mount

MultiForceTM
MF
Resistance System

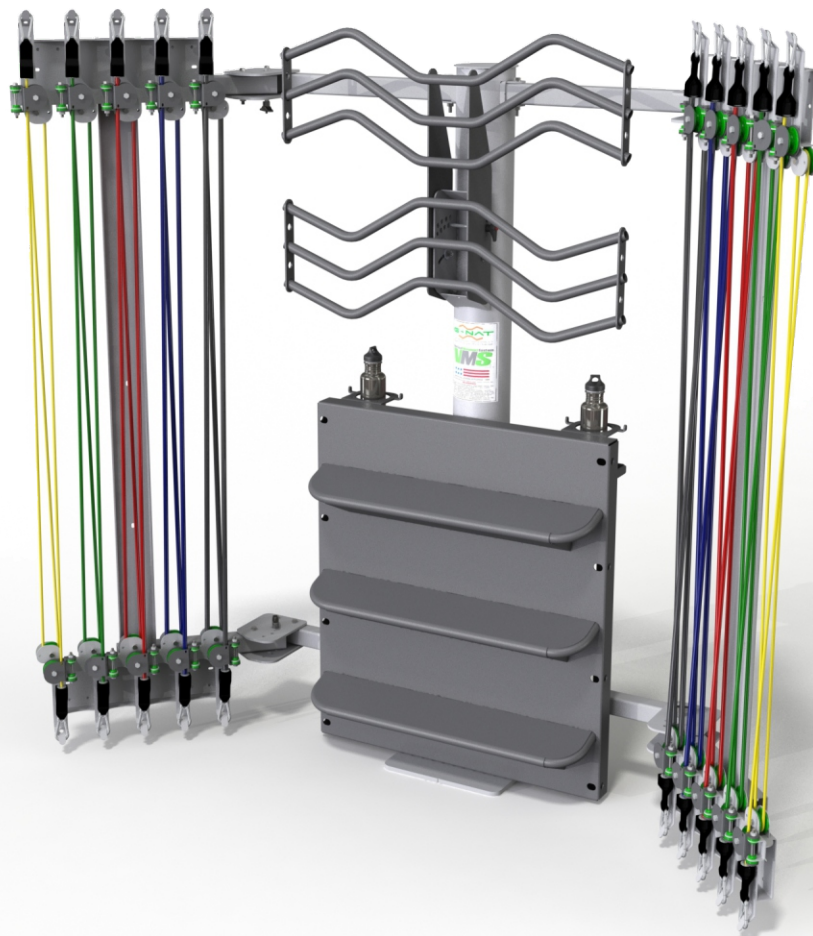

g-nat.com

Made in the USA

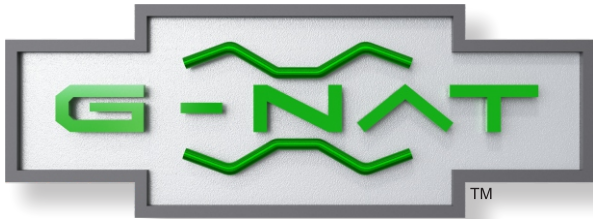

V4MF5

Combo Floor Mount

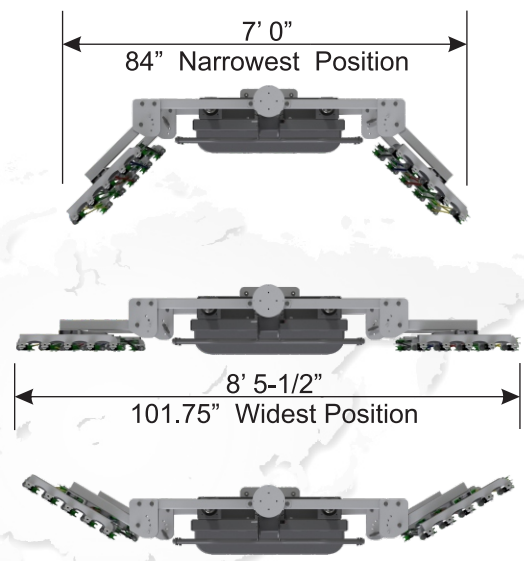
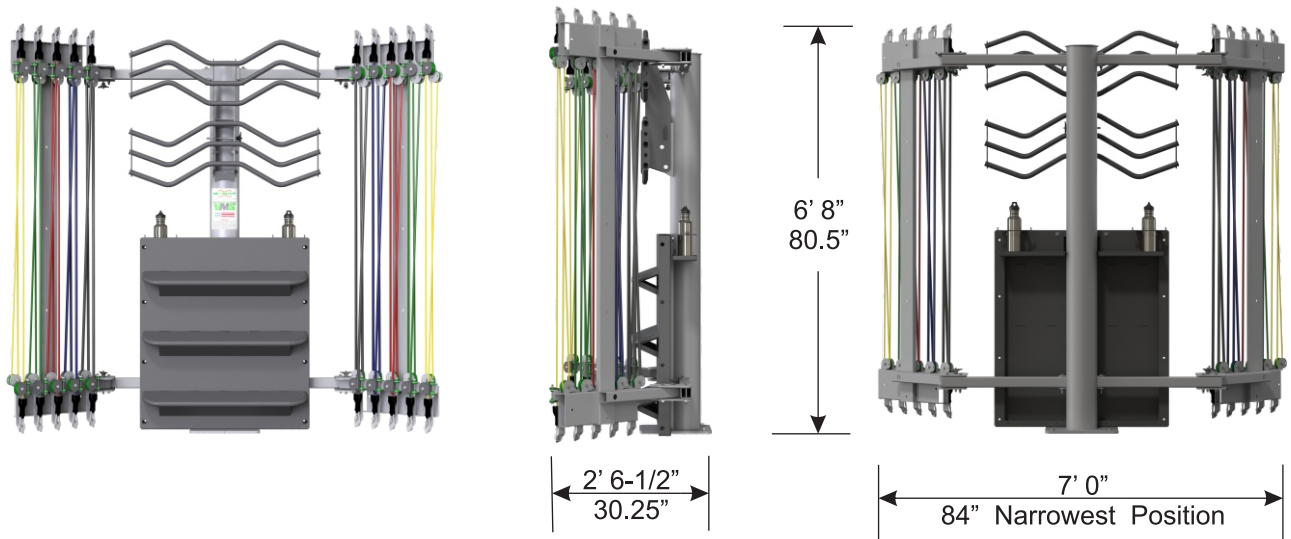

The V4MF5 is a compact multi-modality system combining both VMS and MultiForce for a multitude of additional movements. This combo system can be used by 1-3 people at the same time by adjusting the band banks to one of four positions. The V4MF5 is perfect for sports specific, occupational, rehab and therapeutic movements. The footprint requires only 4.5 sq. feet of floor space, whether installed in front of a wall or in the middle of the room. It can be installed in places traditional exercise and fitness equipment cannot. Its shared-space design allows the floor space in front of it to be reclaimed for many other daily uses.

The V4MF5 is designed to anchor to a concrete floor. (4 concrete wedge anchors included)

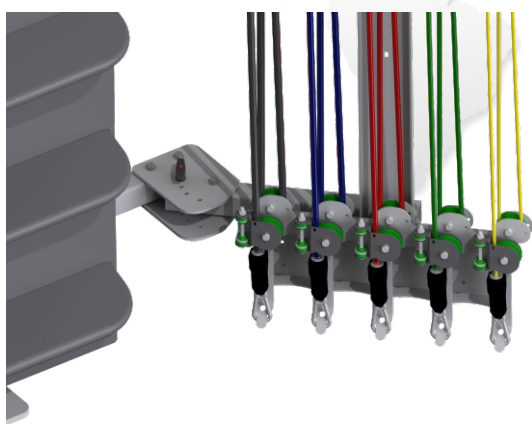

Band banks can be adjusted quickly with the top and bottom pins to any of four positions.

Overall Dimensions & Weight:
101.75"W x 30.5"D x 80.5"H
360 lbs.

Shipping Specifications:
68"L x 40"W x 86"H
425 lbs.
Class 70